



Hydrogen Gas Sensor H2/SA-1000

H2 Gas Sensor in Standard Housing

Applications

- Safety and Process Control
- H2 Detection in H2/CO-Mixtures
- Medical Applications

Measurement

Operation Principle	3-Electrode Electrochemical
Nominal Range	0 - 1000 ppm
Maximum Overload	2000 ppm
Inboard Filter	To remove CO
Output Signal	28.5 ± 11.5 nA/ppm
Resolution (Electronics dependent)	< 1.8 ppm
T90 Response Time	< 40 s
Typical Baseline Range (pure air, 20°C)	-10 ppm to 10 ppm
Maximum Zero Shift (+20°C to +40°C)	20 ppm
Repeatability	< 2 % of signal
Output Linearity	Linear
Gain (Only applies to 4-Electrode sensors)	-

Performance data recorded at 20 – 25 °C, 30 - 50% RH, 900 - 1100 mbar

For further information about usage of Membrapor sensors, see application note [MEM1](#). The data contained in this document is for guidance only. Membrapor AG accepts no liability for any consequential losses, injury or damage resulting from the use of this document or from any omissions or errors herein. Customers should test under their own conditions to ensure that the sensors are suitable for their own requirements.



Hydrogen Gas Sensor H2/SA-1000

Electrical

Rec. Load Resistor	10 - 33 Ω
Bias (V_Sens-V_Ref)	not recommended
Conformity to RoHS directive	RoHS Compliance

Environmental

Relative Humidity Range	15 % to 90 % RH non-condensing
Temperature Range	-40 °C to 50 °C
Pressure Range	Atmospheric \pm 10%
Pressure Coefficient	N.D.
Humidity Effect	None

Lifetime

Expected Operation Life	2 years in air
Expected Long Term Output Drift in air	< 2 % signal loss per month after stabilization
Filter Life	N.D.
Storage Life	6 months in container
Rec. Storage Temperature	5°C - 20°C
Warranty Period	12 months from date of dispatch

Performance data recorded at 20 – 25 °C, 30 - 50% RH, 900 - 1100 mbar

For further information about usage of Membrapor sensors, see application note [MEM1](#). The data contained in this document is for guidance only. Membrapor AG accepts no liability for any consequential losses, injury or damage resulting from the use of this document or from any omissions or errors herein. Customers should test under their own conditions to ensure that the sensors are suitable for their own requirements.



Hydrogen Gas Sensor H2/SA-1000

Standard-Size Outline Dimensions

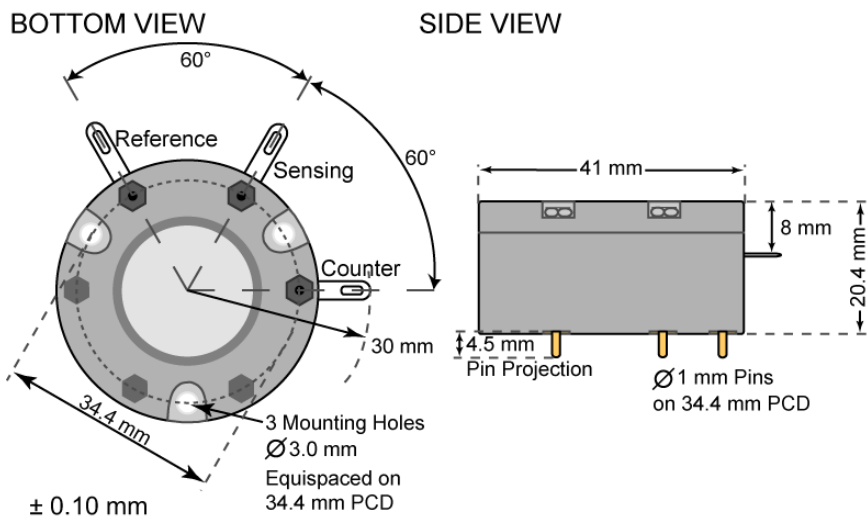

Mechanical

Weight	32 g
Orientation	Any
Housing material	Polycarbonate

Performance data recorded at 20 – 25 °C, 30 - 50% RH, 900 - 1100 mbar

For further information about usage of Membrapor sensors, see application note [MEM1](#). The data contained in this document is for guidance only. Membrapor AG accepts no liability for any consequential losses, injury or damage resulting from the use of this document or from any omissions or errors herein. Customers should test under their own conditions to ensure that the sensors are suitable for their own requirements.



Hydrogen Gas Sensor H2/SA-1000

Cross Sensitivity Data

The table below does not claim to be complete. Interfering gases should not be used for calibration. Please contact Membrapor AG for further support regarding cross sensitivities.

Interfering Gas	Concentration [ppm]	Reading [ppm]
CO	600	< 18

Important Application Notes

- Disinfection solutions containing alcohols and other VOCs must be avoided.
- The CO cross sensitivity in the table is valid for temperatures $\geq 20^{\circ}\text{C}$.
- The CO cross sensitivity can be $> 5\%$ for temperatures $< 0^{\circ}\text{C}$.

Performance data recorded at 20 – 25 °C, 30 - 50% RH, 900 - 1100 mbar

For further information about usage of Membrapor sensors, see application note [MEM1](#). The data contained in this document is for guidance only. Membrapor AG accepts no liability for any consequential losses, injury or damage resulting from the use of this document or from any omissions or errors herein. Customers should test under their own conditions to ensure that the sensors are suitable for their own requirements.